

1.

2.

3.

4.

	(900...1350)±5
	350±5
	670±5
	40

( . .1):

		./ .
1		1
2		1
3		1
4		3
5	10 40	6
6	10	6

5.

( " " ) .1)

( " " ) .1) .2.

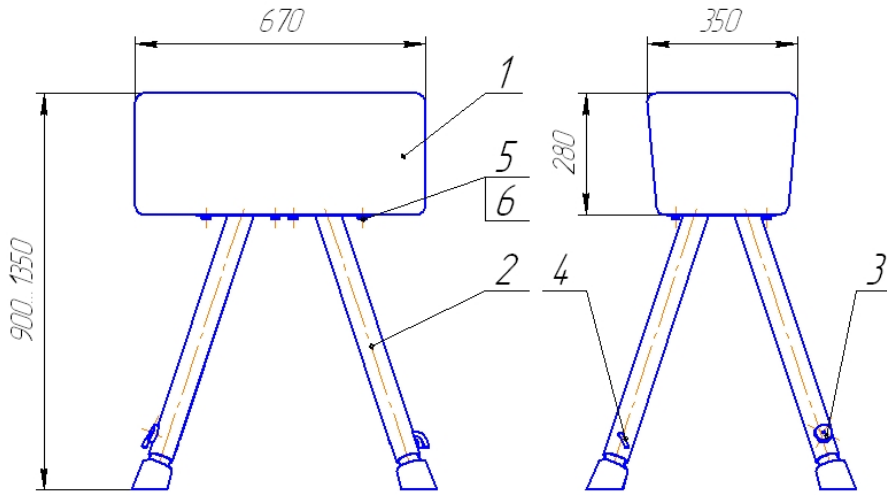

.1

6.

.3

.4

7.

8.

- 12

9.